

UNIT PURE AIR CONTROL 800:

Model: PAC800
 Airflow: CONSTANT 800M³/H
 Available pressure: 100PA
 Fan - RPM: 4120RPM
 Motor: 0,338KW / 230V / 50-60HZ

FILTRATION STEPS:

Prefilter: G4
 Gas filter: GRSYSTEM
 Absolute filter: HEPA H13
 Approximate weight: 82.5KG

ACCESORIES INCLUDED:

. Diferential pressure switch in the filtration steps G4 & H13
 . 4 units of Diam 10 fixing brackets

VERSION:

- V.01

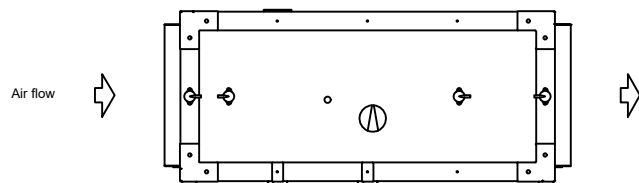
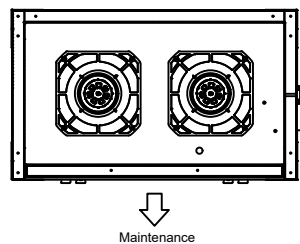
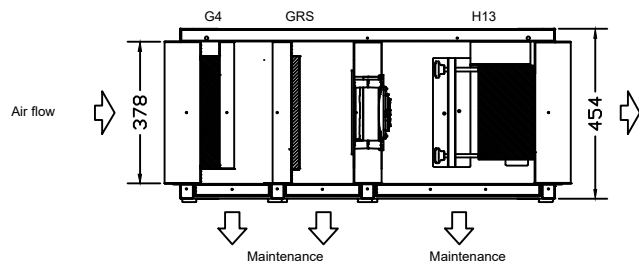
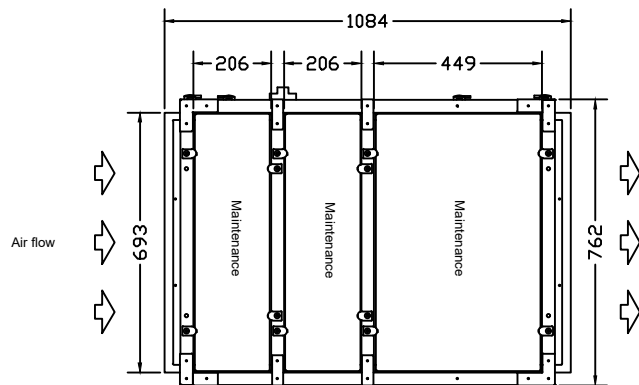

Fan lw - dB (A)	63Hz	125Hz	250Hz	500Hz	1000Hz	2000Hz	4000Hz	8000Hz	dB(A)
Aspiration	60	59,5	63,9	66,1	66,1	63,2	59,3	56,7	70,3
Discharge	65	64,5	68,9	71,1	71,1	68,2	64,3	61,7	75,3
Radiate	45	45	56	61	62	63	59	56	67,1

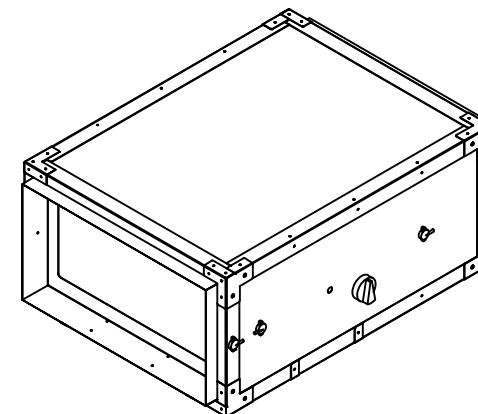

Notes:

- 1.- The filter maintenance is performed by the bottom of the unit
- 2.- Unit of measurement: mm.

Maintenance side: BOTTOM
 Conection side: RIGHT
 Situation unit: INDOOR
 Bench: NO
 External finishing: PAINTED

Internal finishing: SMOOTH
 Fan internal finishing: SMOOTH
 Insulation tape: PUR
 Insulation thickness: 30mm
 Remarks: -

Client: XXXXXX
 Project Number: XXXXXX

Model: PA800
 Escale: S.E.
 Date: XX-XX-XXXX
 Drawing by: LEM
 Checked: SNB

